

Illustration - Type - E

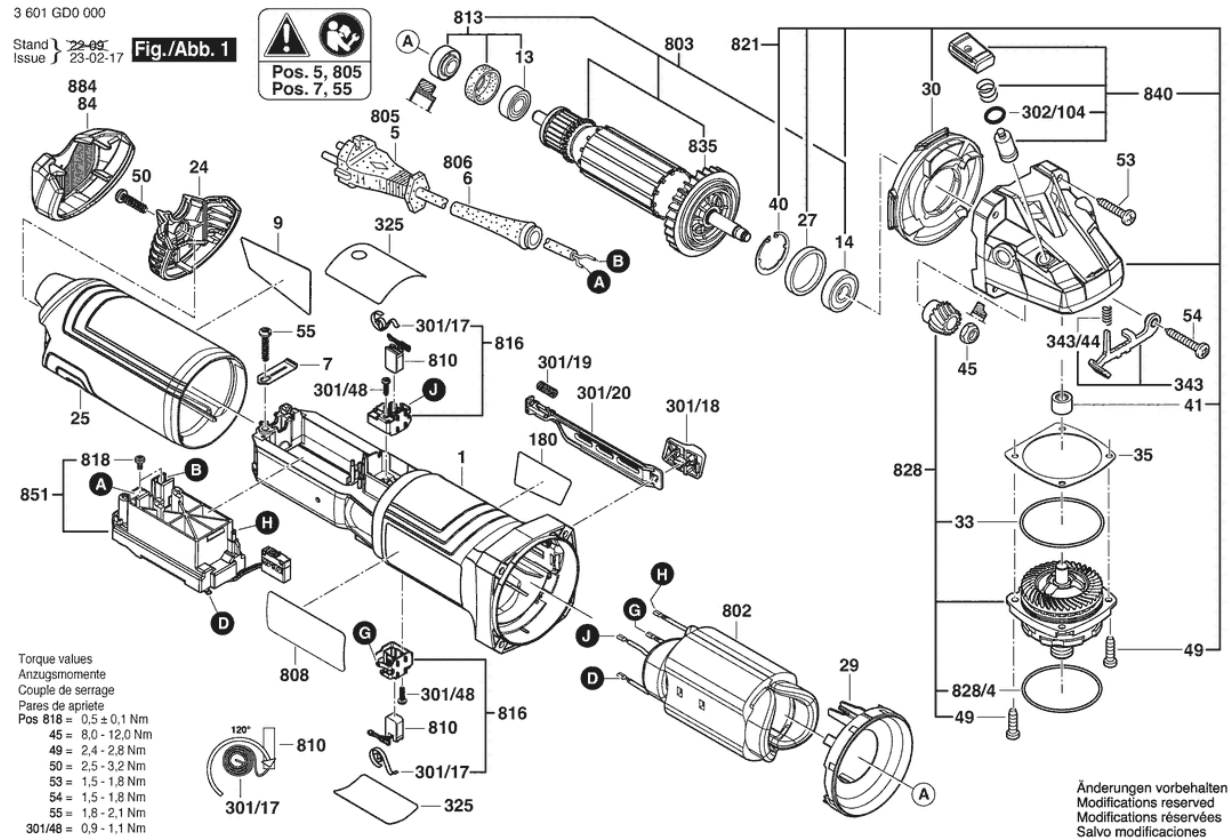
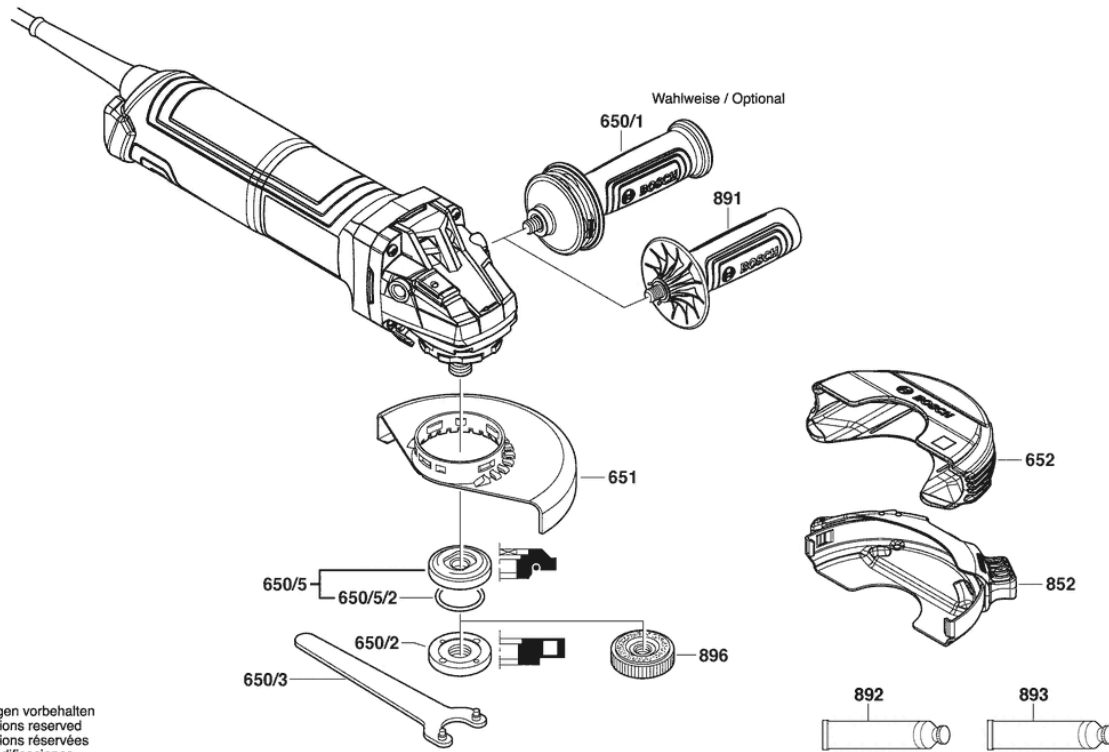

Illustration - Type - E

3 601 GD0 000

Stand } 22-03-23 **Fig./Abb. 2**
Issue }



Spare parts list

Item	Part Number	Description	Illustration
1	1 605 108 2K7	Motor Housing	1
6	1 600 703 043	Grommet	1
7	1 601 302 017	Fastening Clamp	1
9	1 601 11C 461	Manufacturer's nameplate	1
13	2 600 905 032	Ball Bearing 7X19X6	1
14	1 600 905 032	groove ball bearing 8X22X7	1
24	1 605 500 2G4	Cover	1
25	1 605 500 2HH	Housing Cover	1
27	1 600 206 025	Rubber Ring	1
29	1 600 591 070	Air-Deflector Ring	1
30	1 600 591 05N	Air Distributor	1
33	1 600 210 035	O-Ring 46,0X1,1 MM	1
35	1 600 136 013	Shim 0,1 MM THICK	1
35	1 600 136 014	Shim 0,2 MM THICK	1
35	1 600 136 015	Shim 0,3 MM THICK	1
35	1 600 136 020	Shim 0,15 MM THICK	1
40	1 600 119 011	Retaining clip	1
41	1 600 200 029	Plain bearing	1
45	1 603 300 016	Hex Nut M7, SW10	1
49	1 603 435 08X	Thread-forming tap. Screw M4X16-ST W/ PRECOTE 85-3	1
50	2 914 201 527	Torx Oval-Head Screw	1
53	1 603 435 078	Torx Oval-Head Screw	1
54	1 603 414 026	Torx Oval-Head Screw 4X30	1
55	2 603 490 023	Torx Oval-Head Screw 4X20	1
180	1 601 11C 45X	Sticker	1
301/17	1 604 652 021	Spiral Spring	1
301/18	1 600 A01 6PW	Switch Handle	1
301/19	1 600 A02 1GL	Compression Spring	1
301/20	1 600 A01 P8K	Adjusting Slide	1
301/48	1 613 435 034	Lens Head Screw 3X10 ST	1
302/104	1 600 210 044	O-Ring 4,5X1,0 MM BLUE	1
325	1 607 000 EK6	Insulating Plate	1
343	1 607 000 742	Catch Lever	1
343/44	1 604 611 042	Compression Spring	1

Spare parts list

Item	Part Number	Description	Illustration
802	1 607 000 F0M	Field	1
803	1 607 000 EJ4	Armature assembly	1
805	1 607 000 392	Power supply cord EU 4,15M 2 X 1,0MM H07 RN-F	1
808	1 601 11A 9G7	Nameplate	1
810	1 607 000 EJ7	Carbon-Brush Set	1
813	1 607 000 V38	groove ball bearing	1
816	1 607 000 EJ9	Brush Holder	1
818	1 607 000 EK5	Pan head screw	1
821	1 607 000 EK1	Gear Housing	1
828	1 607 000 E1D	Bearing Flange	1
828/4	3 600 210 109	O-Ring 47,0X1,5 MM	1
835	1 606 610 17B	Fan	1
840	1 607 000 V41	Push-Button	1
851	1 607 000 F57	Speed governor	1
884	1 600 A02 1FX	Filter	1
650/1	1 602 025 0A0	Auxiliary Handle	2
650/2	1 603 345 043	Round Nut M14	2
650/3	1 607 950 052	Pin-Type Face-Wrench	2
650/5	2 605 703 014	Clamping Flange Ø22,3XØ42 MM	2
650/5/2	1 600 210 039	O-Ring 20,35X1,78 MM	2
651	1 600 A02 E9M	Protective Cover	2
652	1 600 A02 1MH	Protective Cover	2
852	1 600 A02 059	Protective Cover	2
891	1 602 025 09T	Auxiliary Handle	2
892	1 615 430 017	Grease Tube 225 ML	2
893	1 615 430 020	Grease Tube 225 ML	2
896	1 600 A01 6PP	Fast Locking Flange	2